

Fulfill your need for speed in the comfort and safety of home.

Get in, buckle up, start your engine and race like a pro.

VirtualGT™, the first and only authentic racing simulator designed for personal use.

What makes VGT different from all other simulators? High-energy 3-dimensional surround sound, intense vibration, accurate force-feedback steering, authentic race seating, and amazing video, all integrated into a visually stunning, self contained chassis. At its core is a sophisticated computerized control system that makes VGT as easy to use as it is addictive to drive. You can be racing your friends head-to-head within a few hours after delivery.

Available with Sony's famous Gran Turismo™ software running on Sony PlayStation®, or a suite of the best auto racing software running on our integrated high performance PC computer. The PC software covers almost every racing series from F1 to Rally, and is preinstalled and preconfigured on dual removable drives. This software is updated with new cars and tracks each quarter.

Cars include race tuned Asian, American, and Euro sports cars, open wheel cars from trainer to F1, off-road rally, and prototypes. Race on real tracks against up to 50 computer controlled cars, or race other VGT drivers in the same room or over the Internet.

A pair of VirtualGTs make a unique and incredibly entertaining addition to any game room or garage. They will provide years of enjoyment for both you, your family and friends who share your passion for driving high performance automobiles.

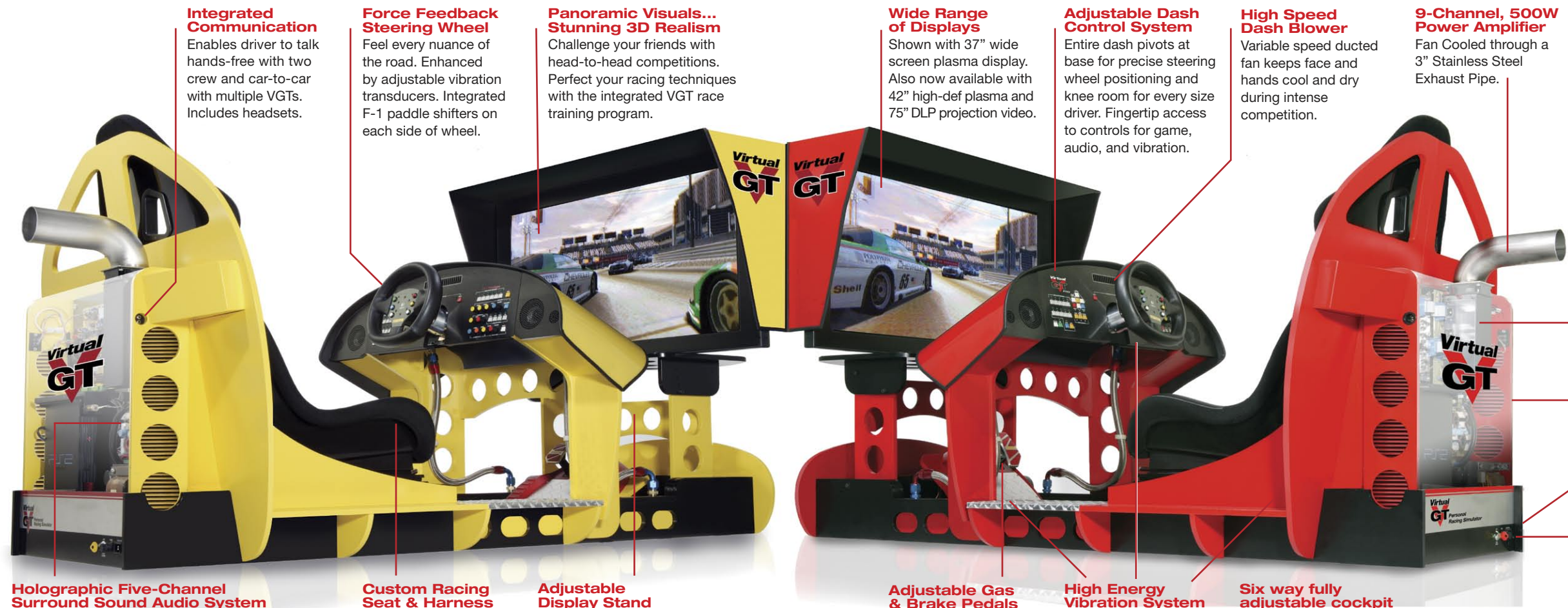

Holographic Five-Channel Surround Sound Audio System

Four satellite speakers and subwoofer put you inside a 3D audio bubble comparable to the best home theater systems. Capable of 100dB SPL to accurately recreate the sound of a 1000 HP engine, tires, wind, and other cars around you. Under-seat subwoofer for intense engine sound and vibration.

Custom Racing Seat & Harness

Extra width, padded for race car look with armchair comfort. Integrated 4-point harness system for maximum contact with seat vibration.

Adjustable Display Stand

Full range of monitors, adjustable height and distance. Non-glare hood.

Adjustable Gas & Brake Pedals

Move fore and aft; rotate for angular adjustment.

High Energy Vibration System

Powerful transducers on pedals, dash, seat bottom and seat back, inject the sensation of racing into your feet, hands, and torso.

Six way fully adjustable cockpit

Unique pivoting dash assembly automatically raises steering wheel adding knee clearance as it pivots forward. Together with the sliding seat and pedals, allows a 7-foot man to race comfortably for hours.

Integrated Communication
Enables driver to talk hands-free with two crew and car-to-car with multiple VGTs. Includes headsets.

Force Feedback Steering Wheel
Feel every nuance of the road. Enhanced by adjustable vibration transducers. Integrated F-1 paddle shifters on each side of wheel.

Panoramic Visuals... Stunning 3D Realism
Challenge your friends with head-to-head competitions. Perfect your racing techniques with the integrated VGT race training program.

Wide Range of Displays
Shown with 37" wide screen plasma display. Also now available with 42" high-def plasma and 75" DLP projection video.

Adjustable Dash Control System
Entire dash pivots at base for precise steering wheel positioning and knee room for every size driver. Fingertip access to controls for game, audio, and vibration.

High Speed Dash Blower
Variable speed ducted fan keeps face and hands cool and dry during intense competition.

9-Channel, 500W Power Amplifier
Fan Cooled through a 3" Stainless Steel Exhaust Pipe.

Obsessively engineered for realism and ease of use... Press one button to recall your favorite car and track combinations, touch another button and apply your preferred audio and vibration feedback levels. Formula 1 style paddle shifters provide split second gear changes for maximum control.



Software Controls
Recall your favorite ten car and track combinations.

Hardware Controls
Recall audio and sensory levels from six presets.

Custom Audio Processor
Converts 2-channel stereo game sound into amazingly accurate surround sound. Enhanced vibration. Adjustable subwoofer. Six memories to store your favorite setups.

Electronics Rack (E-Rack)
Fully connectorized. Easily removable for upgrade or repair, Protected by clear polycarbonate cover.

Integrated Suspension System
Four corner adjustable independent suspension decouples the chassis from the floor giving VGT it's own energy.

Key Switch for Security
Master power controlled by removable key. Prevents unauthorized use.

Gran Turismo is a trademark of Sony Computer Entertainment America, Inc. All manufacturers, cars, names, brands and associated imagery featured in this game are trademarks and/or copyrighted materials of their respective owners. All rights reserved. ©Sony Computer Entertainment Inc. "PlayStation" is a registered trademark of Sony Computer Entertainment Inc.

SPECIFICATIONS:

AUDIO ELECTRONICS

Amplifier:	9 Channels	
1 - Pedal Vibration		60Wrms
2 - Wheel Vibration		60Wrms
3 - Seat Lo Vibration		60Wrms
4 - Seat Hi Vibration		60Wrms
5 - Subwoofer		140Wrms
6 - Front L Speaker		30Wrms
7 - Front R Speaker		30Wrms
8 - Rear L Speaker		30Wrms
9 - Rear R Speaker		30Wrms

AUDIO CONTROLS:

Pedal Vib Level
Wheel Vib Level
Seat Vib Level
Master Vib Level
Subwoofer Frequency
Subwoofer Level
Speaker Volume
Front/Rear Balance
Headset Level
Comm Level
Mute
Six Presets with Memory button

AUDIO TRANSDUCERS

Speakers:
[4] 3" Aluminum Cone Mid/Woofers
[4] 3/8" Polycarbonate Dome Tweeters
[1] 8"D Carbon Fiber Subwoofer
[4] Custom 10-Element Passive Crossover Networks

Vibration:
[4] Transducers

STEERING

Force Feedback with cooling fan
Rotation: Race Mode - 180 degrees
Rally Mode - 900 degrees
Diameter: 10.75"
Construction: Rubber Grip
[6] control buttons on center section

PEDALS

Accelerator and Brake are proportional and can be used simultaneously.

GAME CONTROLS

Game Controls built onto Left Dash
*10 x 4 [40] 128 step Macros for 1-button access to favorite cars and tracks. Memory Card supplied with 40 factory defaults [overwrite with your own as desired]
* PlayStation only

COMM SYSTEM

Full Duplex 600 Ohm bus with 3 stations per car.
Supplied lightweight headsets with noise cancelling boom mic.
[2] Stereo [1] Mono

Comm System is extendible between multiple cars.
30 Ft. long cable supplied with each additional car on multi-car orders. Each car equipped with [2] Input/Output jacks for connections between cars.

ADJUSTABILITY

Seat: 4.5" travel fore and aft
Pedals: 9" travel fore and aft
20 degree rotation to adjust angle

Dash Yoke: Pivots plus/minus 12 degrees from vertical.
This has the net effect of changing the height of the steering wheel, knee clearance, and distance from the wheel as follows [based on vertical dash reference:

Steering Wheel Height: +3.3" to -3.8"
Steering Wheel Distance: +6.6" to -4.6"
Knee Room from Floor Board: +1" to -3"

WARRANTY

VirtualGT is warranted against defects in materials and workmanship for a period of 2 years after delivery. During this period, Virtual-E Corp will assist you in locating, removing, and returning to us any defective assembly for repair or replacement at no charge.

DELIVERY

VirtualGT is hand-built entirely in the USA in 60-90 days. Each unit is carefully crated for door-to-door shipment to any address in the world within 3 days.

PHYSICAL

Overall Dimensions: 38"W x 74"L
Weight: Chassis [as crated] 90 lbs.
Seat 35 lbs. E-Rack 45 lbs.
Power: 120VAC, 50-60 Hz, 600 Watts
Voltage Converter with plug adapter available for operating [2] VGT Cars anywhere in the world.
Standard colors Red.
Optional colors: Yellow, Green, Blue, Orange, Metallic Silver.

SPACE REQUIREMENTS

A single car requires 8 ft. x 6 ft. or less with single side access.

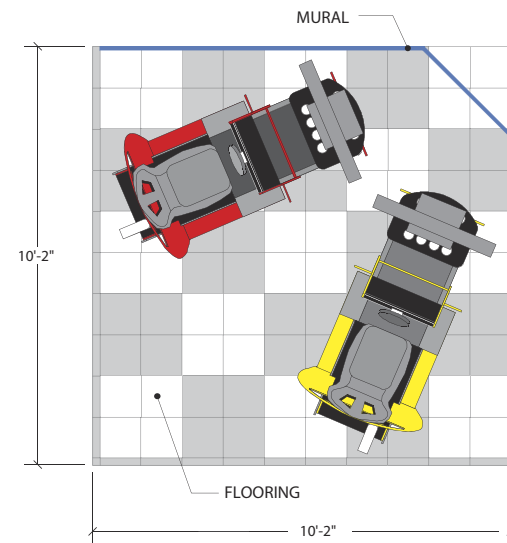

Don't Just Sit There



**Virtual
GT**™ The World's Finest
Personal Racing Simulators

VirtualGT is manufactured in the USA by the Virtual-E Corporation.

P **PARK PLACE LTD**
LUXURY, SPORTS & SPECIAL INTEREST AUTOMOBILES

(425) 562 1000
13710 Northup Way, Bellevue WA 98005
www.parkplaceltd.com